



Industrial Control Systems

Chapter One: Introduction To Automatic Control Systems

Dr. Eng. Baha'eddin Alhaj Hasan
Department of Industrial Engineering



Introduction

In any industrial plant the aim is to produce standard and high quality products and sell them at prices which make profit. These purposes can be achieved in a successfully designed and controlled processes.

What is A process Control?

An industrial process control or simply process control is the deploying of industrial control systems and control theory to monitor and adjust an industrial process to give a desired output. It is used in industry to maintain quality and to improve performance. Which could not be achieved purely by human manual control.

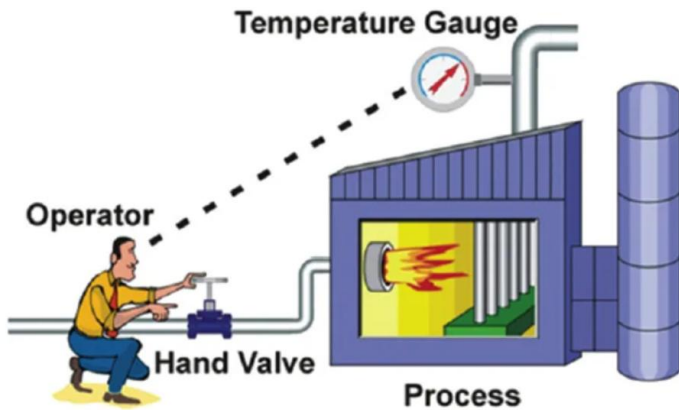

Human-Aided Control

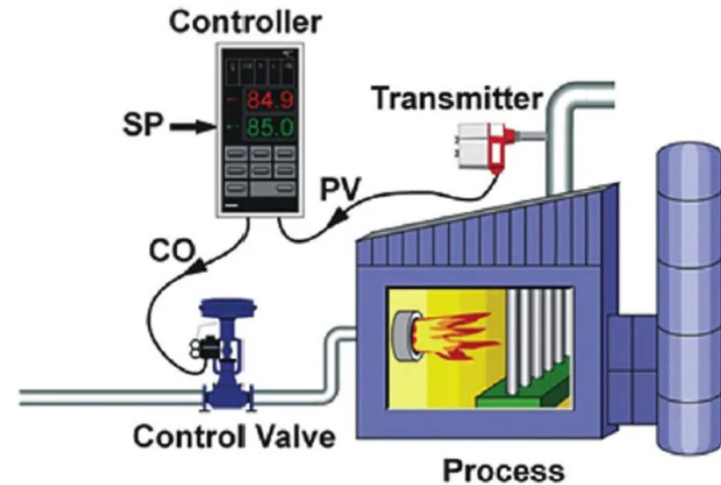

Automatic Control

Example: Temperature closed loop process Control

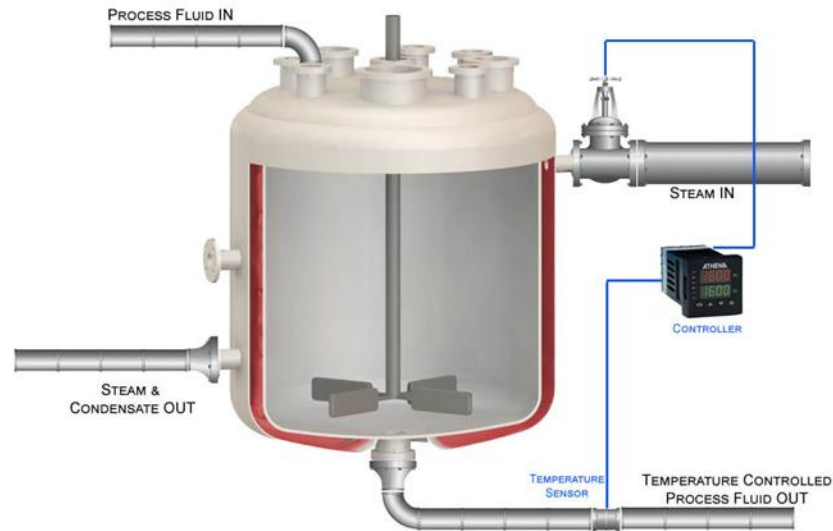

<https://www.youtube.com/watch?v=maQyGdgvS4M>

The concept of a system

What is **a system**?

A **system** is a **collection of parts, components or devices**, that act together, within some boundary, to accomplish a **specific objective**.

A system may represent a **purely physical structure** or just a **set procedures**.

The concept of a system

All '**systems**' have three things in common; they all require **input(s)** and involve a **process** to produce **output(s)**.

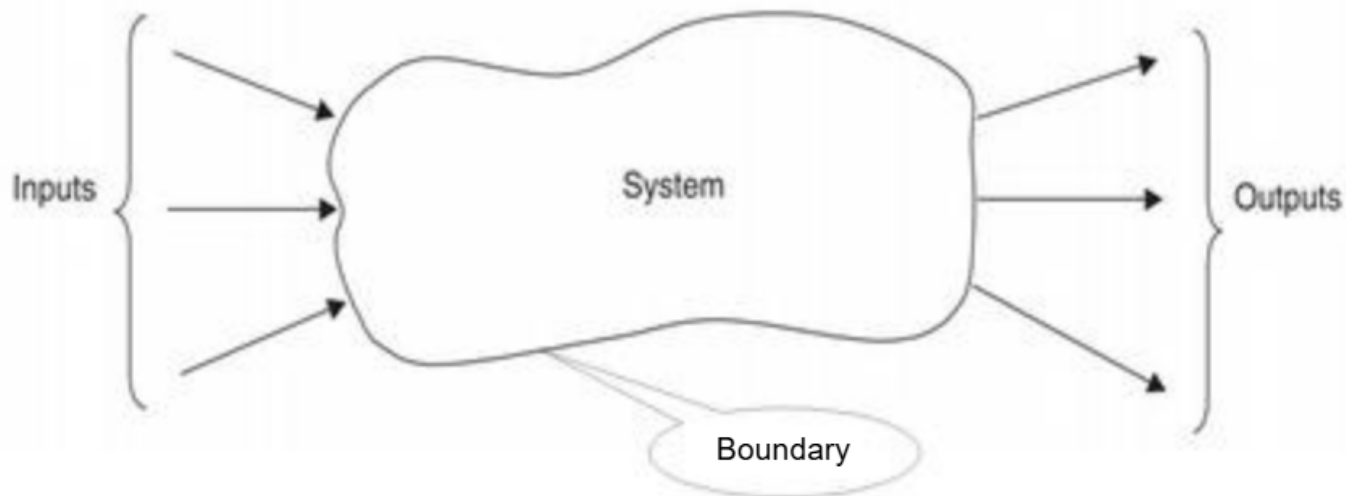



Figure 1: A '**system**' can be viewed as a **black box** which takes in **input signal(s)** and **processes** the input to generate the **output signal(s)**.

The concept of a system

The **three basic elements of a system** are therefore the **input(s)**, the **process** and the **output(s)**.

The **output** is the **specified action of the process** on the **input(s)**.

A series of actions; electrical, chemical, mechanical etc., performed on the input(s) to produce the output(s) is known as the **process**.



What is A Control System?

Control is the **power to influence or direct the behaviour** of person, a **system** or an environment.

A control system is therefore **an arrangement of components or devices...**

...that act together to **manage, command, direct or regulate the behaviour of a system to achieve a desired output...**

...regardless of the **changing conditions** of the system.





What is A Control System?

- A system Controlling the operation of another system.
- A system that can regulate itself and another system.
- A control System is a device, or set of devices to manage, command, direct or regulate the behaviour of other device(s) or system(s).



What is A Control System?

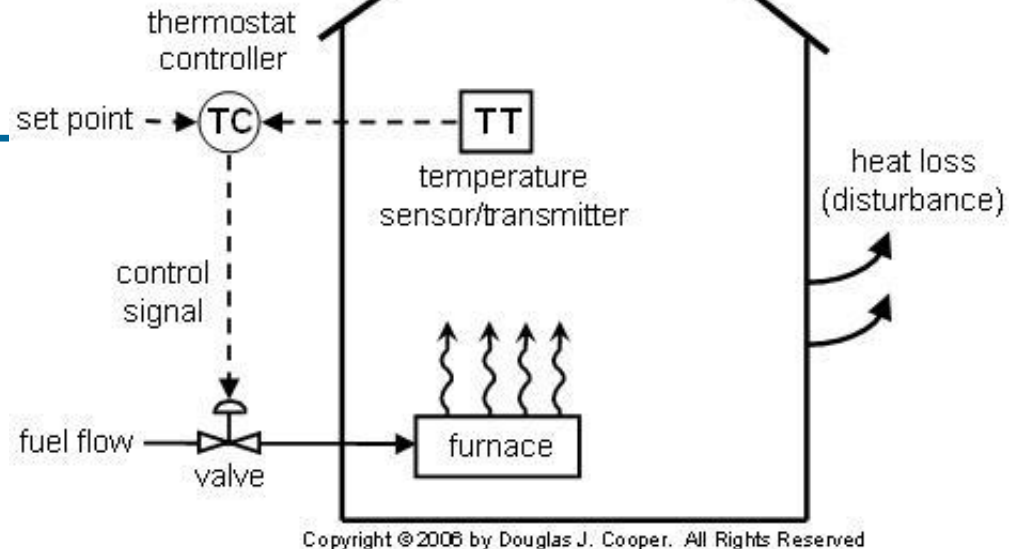

Consider a house in a cold climate which is to be maintained near a desired temperature by circulating hot water through a heat exchanger

- Temperature of the room is determined by a thermostat
- This temperature is compared with the desired temperature or range of temperature
- If the temperature is below than the desired, the furnace and the pump are turned on; if the temperature is above the furnace and pump are turned off.



What is A Control System?

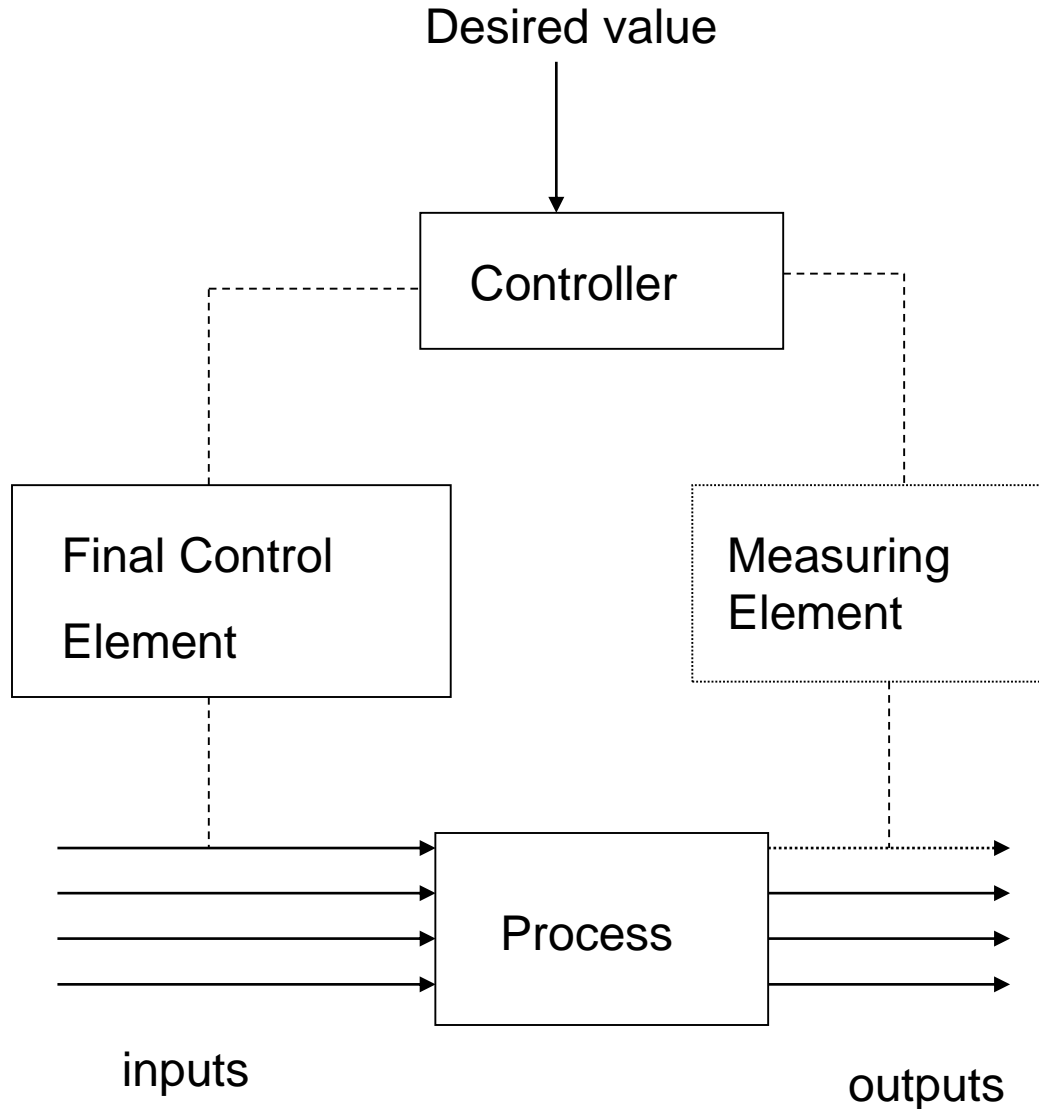



What is A Control System?

Input refers to a variable that causes an output.

Heated room example;

input: fuel to the furnace

output: room temperature



What is A Control System?

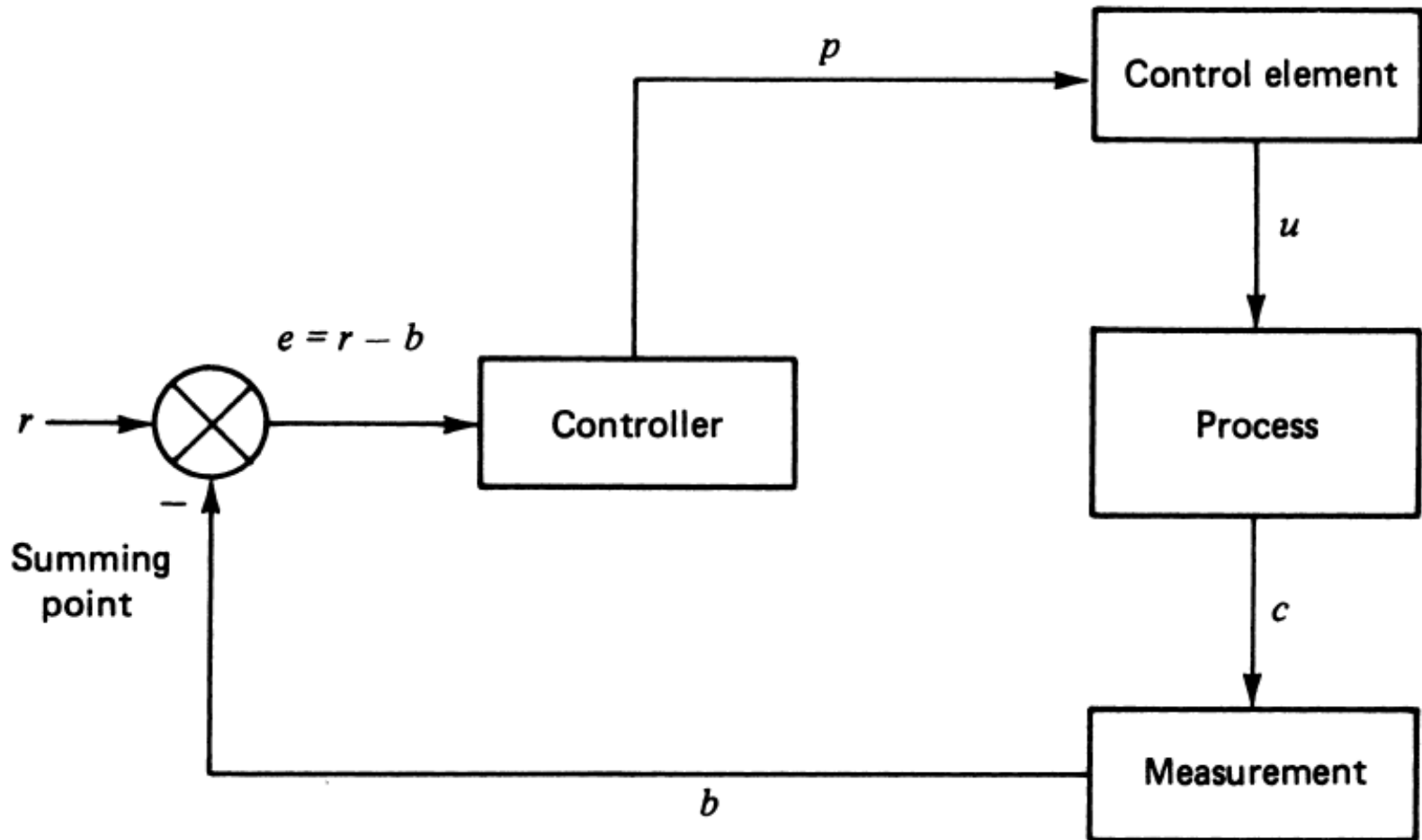



Control Terminology

- Controlled variables - these are the variables which quantify the performance or quality of the final product, which are also called output variables.
- Manipulated variables - these input variables are adjusted dynamically to keep the controlled variables at their set-points.
- Disturbance variables - these are also called "load" variables and represent input variables that can cause the controlled variables to deviate from their respective set points.



Control Terminology

- Set-point change - implementing a change in the operating conditions. The set-point signal is changed and the manipulated variable is adjusted appropriately to achieve the new operating conditions.
- Disturbance change - the process transient behaviour when a disturbance enters, also called regulatory control or load change. A control system should be able to return each controlled variable back to its set-point.



Control Terminology

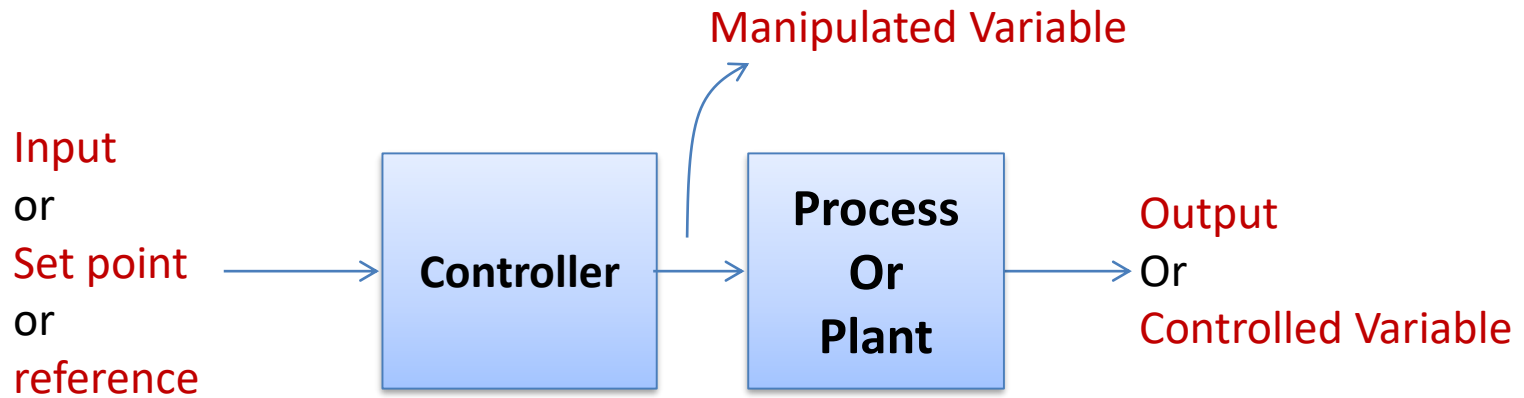



Why is Control Necessary?

There are two main reasons for control:

- The first reason for control is to maintain the measured variable at its desired value when disturbances occur.
- The second reason for control is to respond to changes in the “desired value”.
- In the analysis of plant operation the desired values are determined by control objectives.



Types of Control System

□ Natural Control System

Universe

Human Body

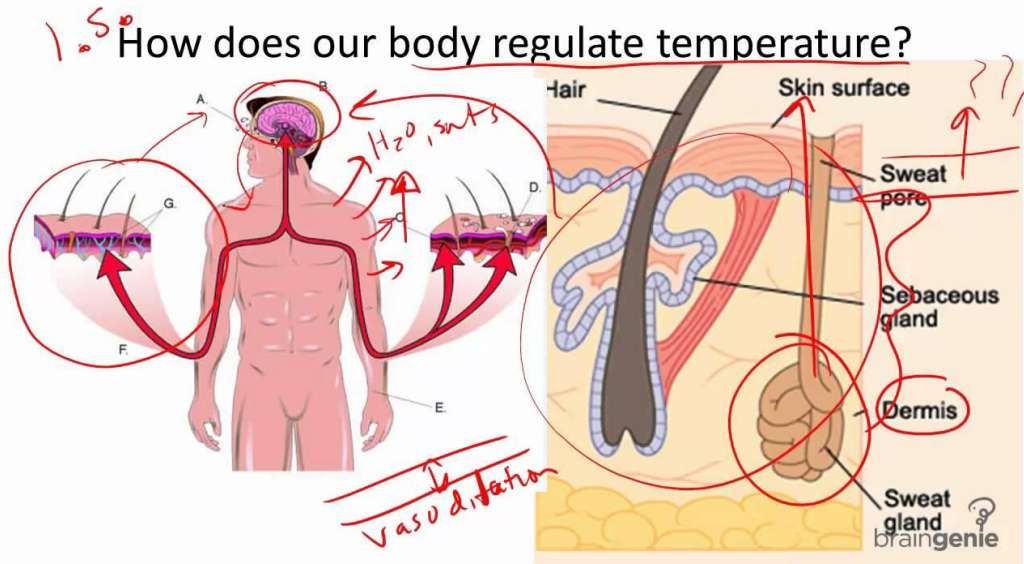



Types of Control System

Manmade Control System

Aeroplanes

Chemical Process

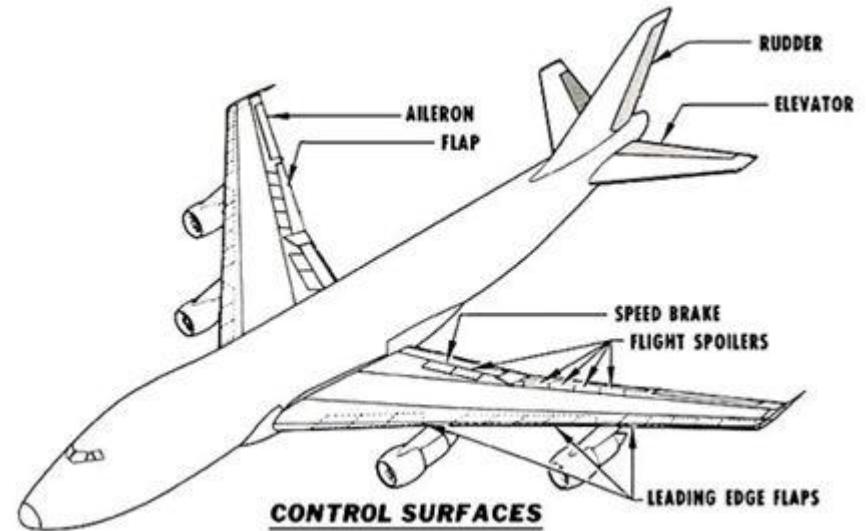
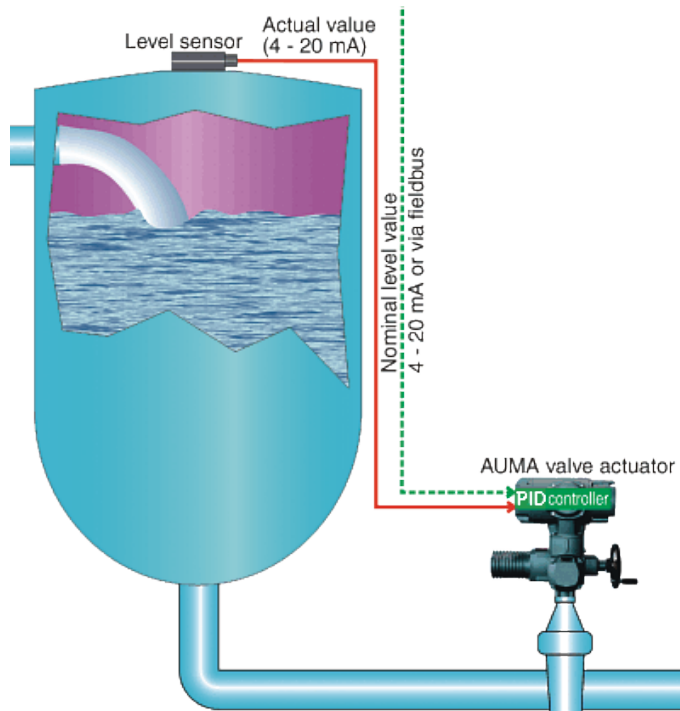



Types of Control System

❑ Manual Control Systems

Room Temperature regulation Via Electric Fan
Water Level Control

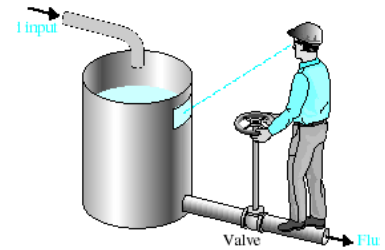

❑ Automatic Control System

Home Water Heating Systems (Geysers)
Room Temperature regulation Via A.C
Human Body Temperature Control





Types of Control System

Open-Loop Control Systems utilize a controller or control actuator to obtain the desired response.

- Output has no effect on the control action.
- In other words output is neither measured nor fed back.

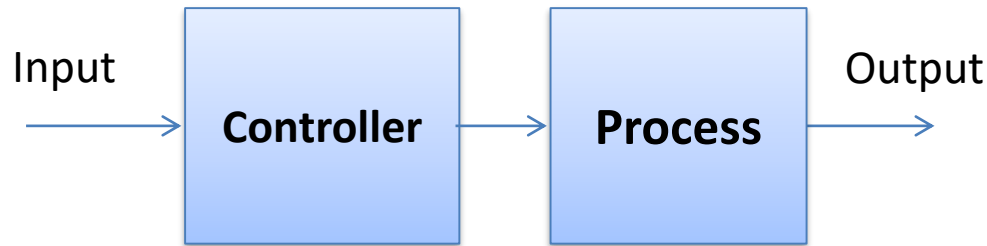

Open-loop control system (without feedback).

Examples:- Washing Machine, Toaster, Electric Fan, microwave oven, e.t.c



Types of Control System

- Since in open loop control systems reference input is not compared with measured output, for each reference input there is fixed operating condition. Therefore, the accuracy of the system depends on calibration.
- The performance of open loop system is severely affected by the presence of disturbances, or variation in operating/ environmental conditions.



Types of Control System

Closed-Loop Control Systems utilizes feedback to compare the actual output to the desired output response.

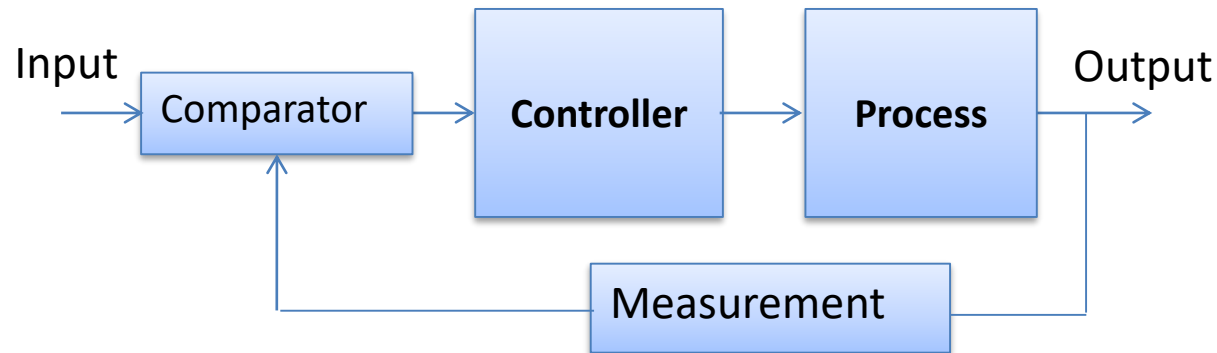

Closed-loop feedback control system (with feedback).

Examples:- Refrigerator, Electric Iron, Air conditioner



Types of Control System

Multivariable Control System

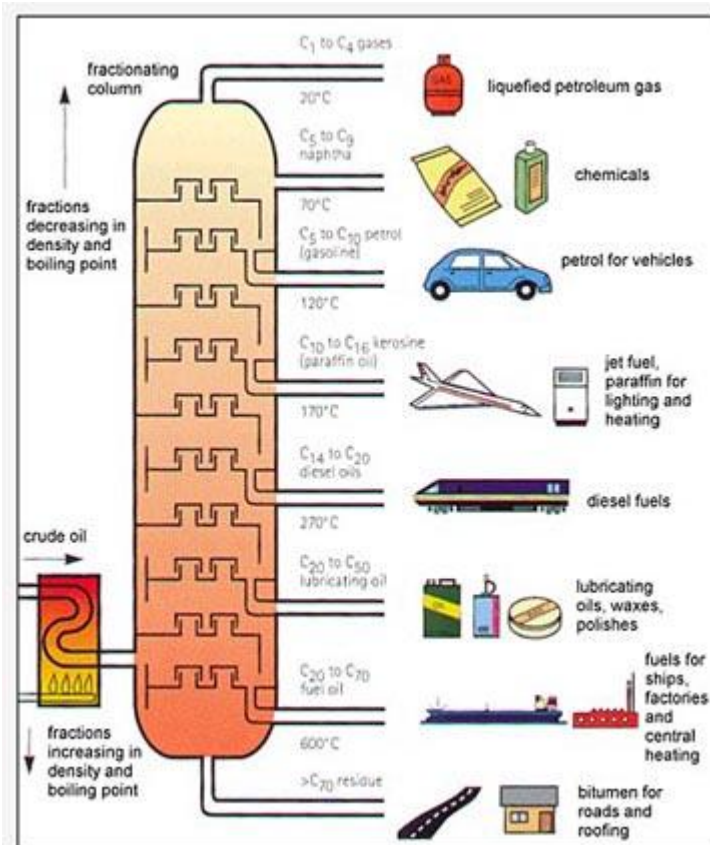
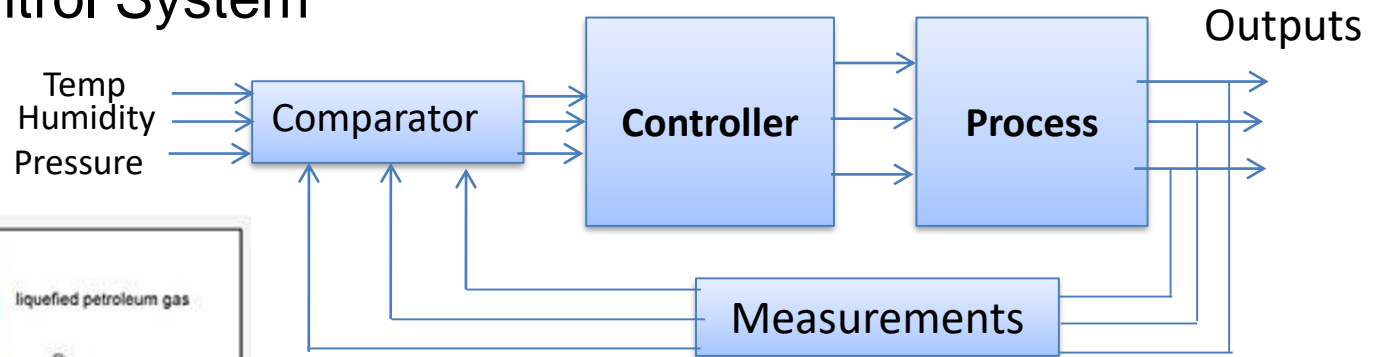



Types of Control System

Feedback Control System

- A system that maintains a prescribed relationship between the output and some reference input by comparing them and using the difference (i.e. error) as a means of control is called a feedback control system.

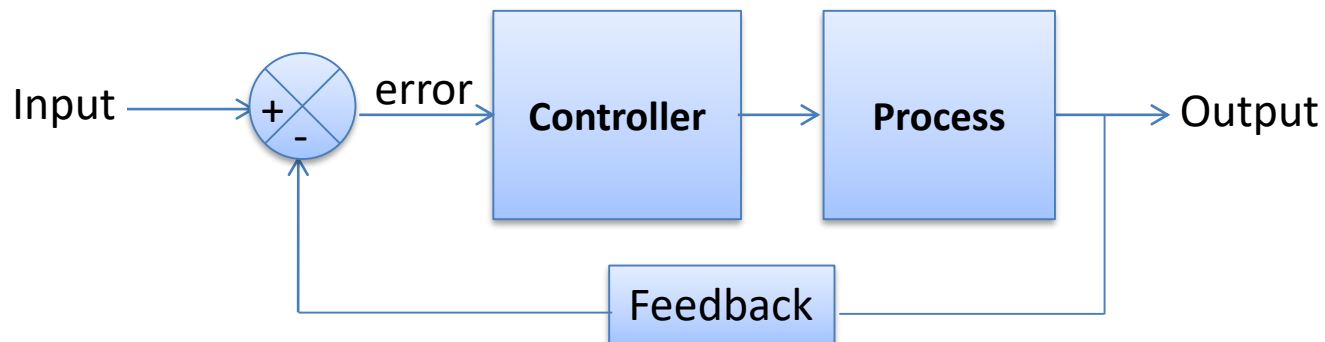

- Feedback can be positive or negative.



Types of Control System

Servo System

- A Servo System (or servomechanism) is a feedback control system in which the output is some mechanical position, velocity or acceleration.

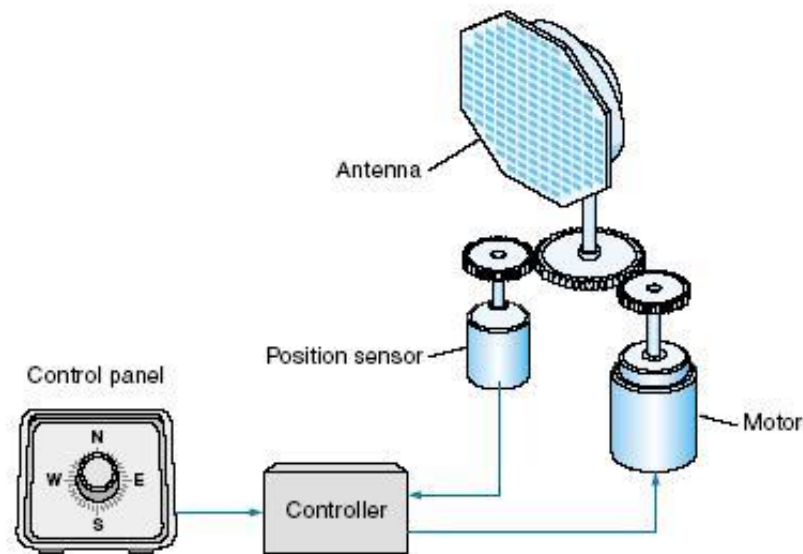

Antenna Positioning System



Types of Control System

Servo System

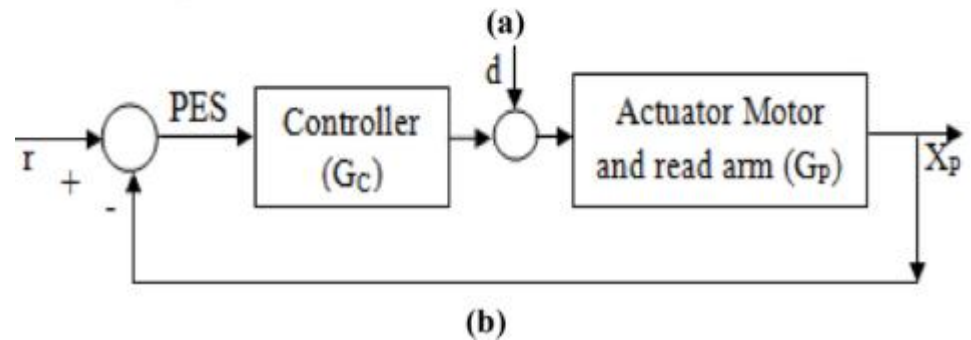
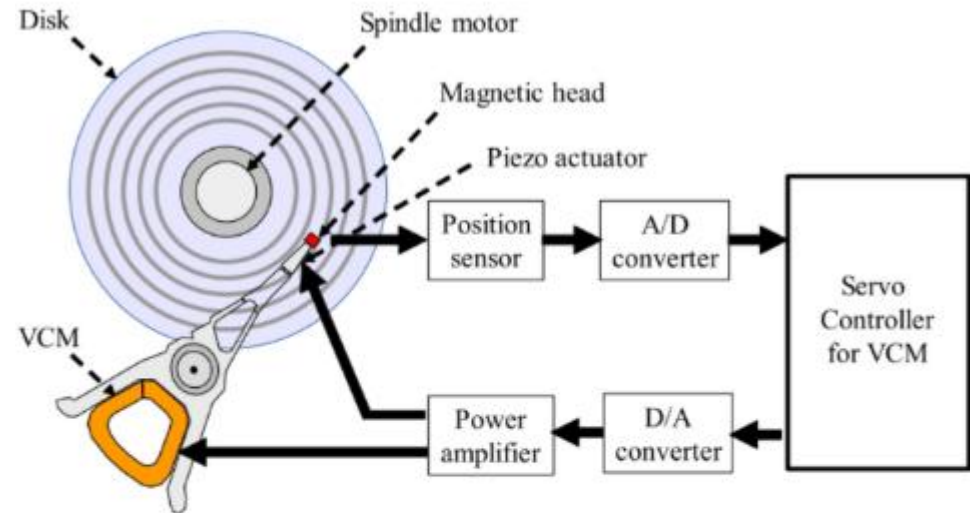
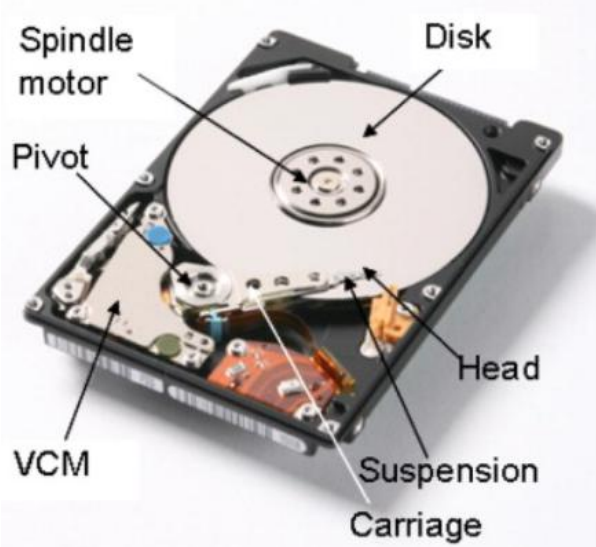

Hard Disk Drive (HDD) Positioning System

The Map of Control Theory

